

# COBRA DS 1200/1800 A

Dry screw vacuum pumps



VACUUM SOLUTIONS



## High performance

Advanced screw design, excellent running qualities, integrated vacuum booster, perfectly suited for solar, flat panel and semiconductor applications and harsh processes with high gas temperatures, such as etch and CVD, excellent powder handling, tantal coated screw for harsh applications

## Efficient

Low cost of ownership, minimal maintenance, long service intervals, high uptime, high hydrogen throughput, low energy consumption, variable temperature control

## Compact

Fit-in-place design, directly mounted canned motor, backing pump and vacuum booster combined on a compact base frame, low vibration level

# COBRA DS 1200/1800 A

Dry screw vacuum pumps



VACUUM SOLUTIONS

Dimensional drawing

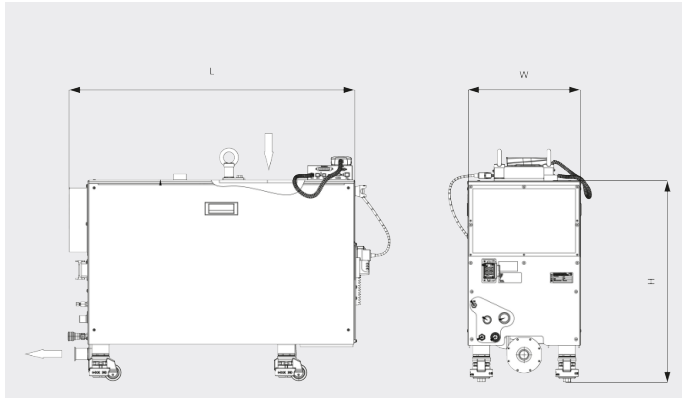

Pumping speed

Air at 20°C. Tolerance: ± 10%

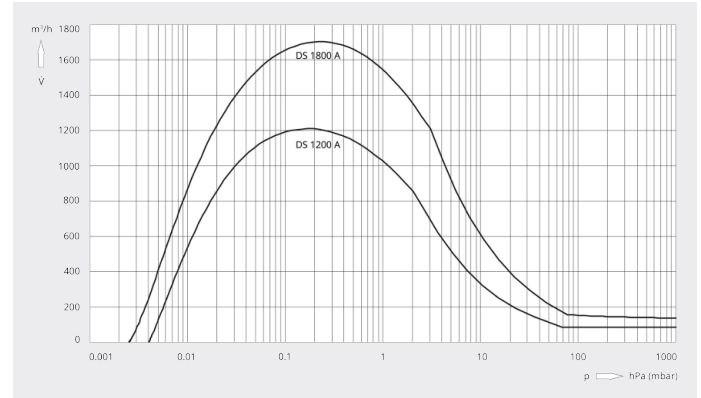

	COBRA DS 1200 A	COBRA DS 1800 A
Nominal pumping speed	1200 m³/h	1700 m³/h
Ultimate pressure	0.003 hPa (mbar)	0.003 hPa (mbar)
Nominal motor rating backing pump	4.0 / 4.4 kW (50 / 60 Hz)	4.4 kW
Nominal motor rating vacuum booster	4.0 kW	4.0 kW
Nominal motor speed backing pump	3000 / 3600 min <sup>-1</sup> (50 / 60 Hz)	5100 min <sup>-1</sup>
Nominal motor speed vacuum booster	5400 min <sup>-1</sup>	5400 min <sup>-1</sup>
Noise level (ISO 2151)	< 62 dB(A)	< 62 dB(A)
Water consumption	7.0–8.0 l/min	7.0–8.0 l/min
Nitrogen consumption	0 – 75 l/min	0 – 75 l/min
Weight approx.	500 kg	700 kg
Dimensions (L x W x H)	1073 x 426 x 740 mm	1073 x 426 x 750 mm
Gas inlet / outlet	DN 160 ISO-K / DN 40 ISO-KF	DN 160 ISO-K / DN 40 ISO-KF

DO YOU WANT TO KNOW MORE?

Get in touch with us directly!  
[info@buschusa.com](mailto:info@buschusa.com) or +1 757 463 7800



CONTACT FORM



CALL NOW